

CRYSTAL UNIT

XTL90

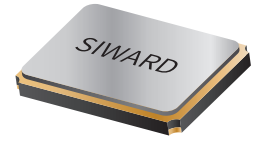

Applications

- Multimedia devices / Bluetooth / Wireless LAN
- Sensor / Camera
- Automotive

Features

- Ultra thin / Dimensions (1.6×1.2×0.35)
- Compliant products with AEC-Q200
- Ceramic Package
- High Reliability and High Stability

Specifications



Model	XTL90	
Nominal frequency range	24.000~60.000 MHz	
Crystal cut	Fundamental [AT-cut]	
Storage temperature range	-40~+125°C	
Operating temperature range	-30~+85°C	-40~+125°C
Frequency temperature characteristics(Ref. to +25°C)	$\pm 15 \times 10^{-6}$	$\pm 50 \times 10^{-6}$
Frequency tolerance (at +25°C)	$\pm 15 \times 10^{-6}$	
Equivalent series resistance	100Ω: 24.000~29.999 MHz 80Ω: 30.000~53.999 MHz 60Ω: 54.000~60.000 MHz	
Load capacitance	8,10,12 pF or specify	
Shunt capacitance	3pF max.	
Level of drive	10 μW (100 μW max.)	

Package quantity: 3,000pcs max./Reel.

Outline and Dimensions [unit:mm]

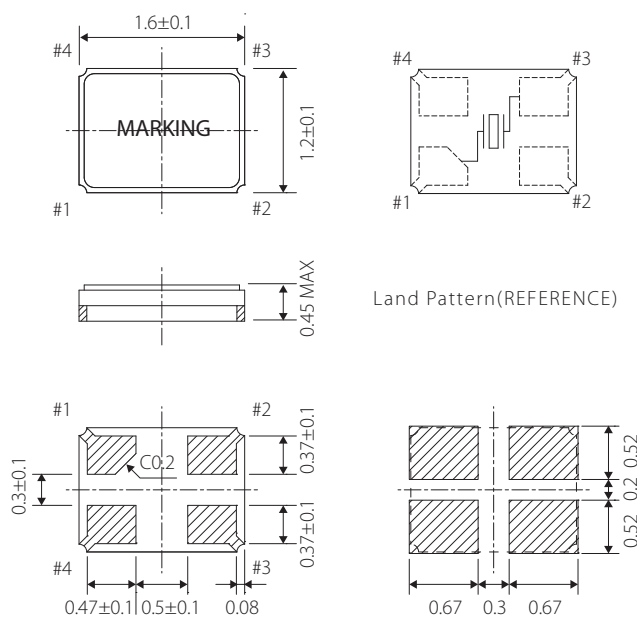

Pin Connection	
#1,#3	Crystal
#2	GND
#4	NC